

SLEWING DRIVE 回转式减速器

WEA25

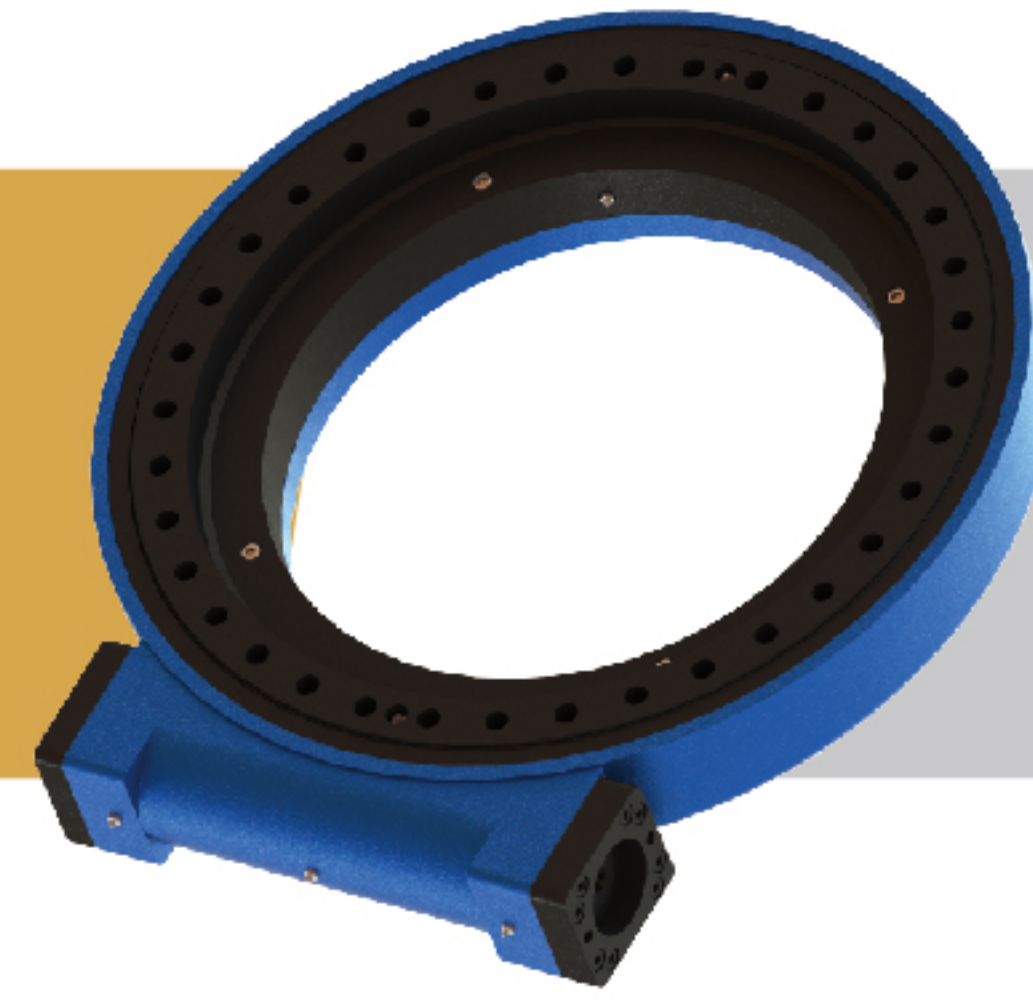

UNITS/单位:mm
1inch=25.4mm

Weight:202kg

FRONT VIEW 正视图

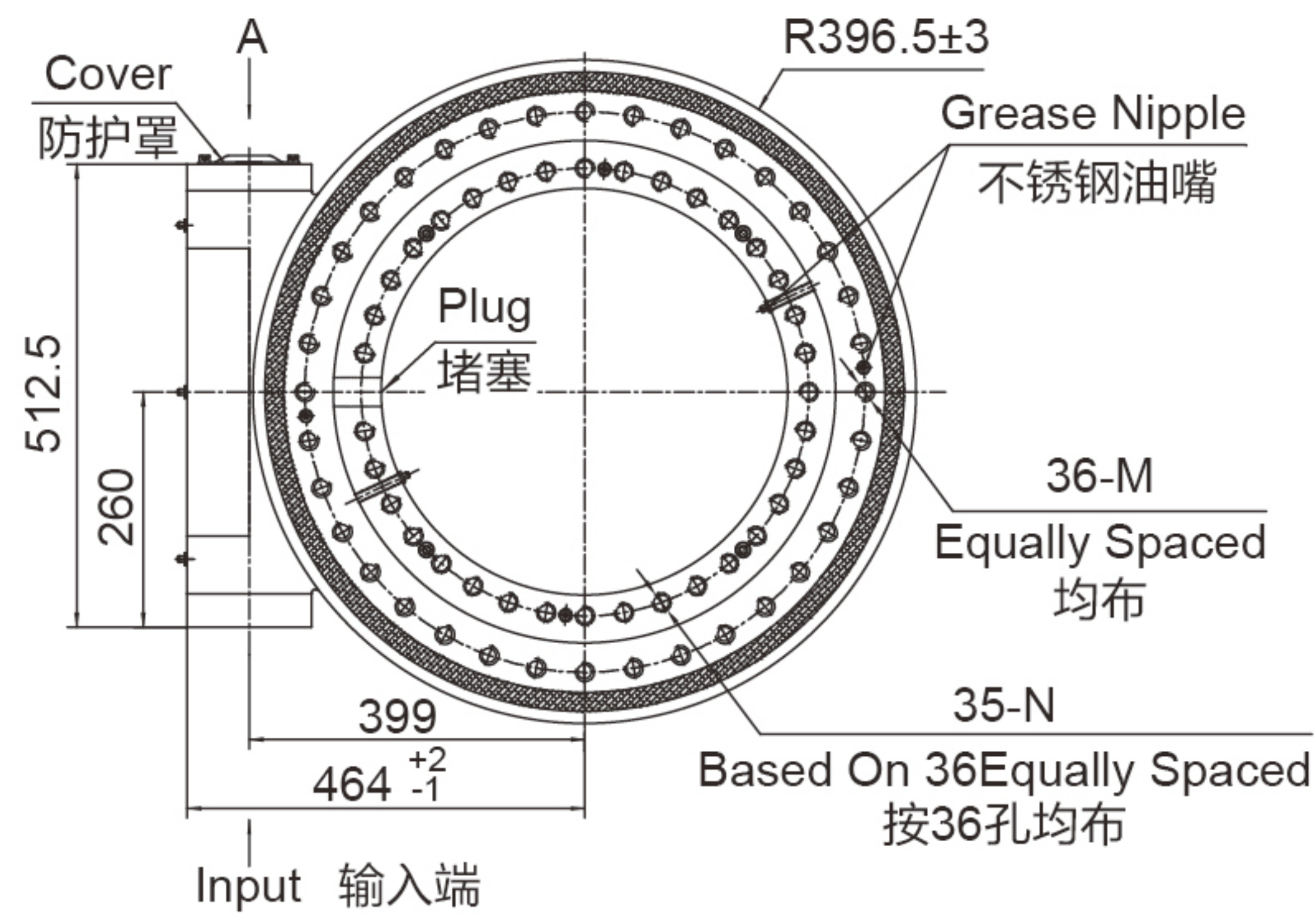

INPUT 输入端视图

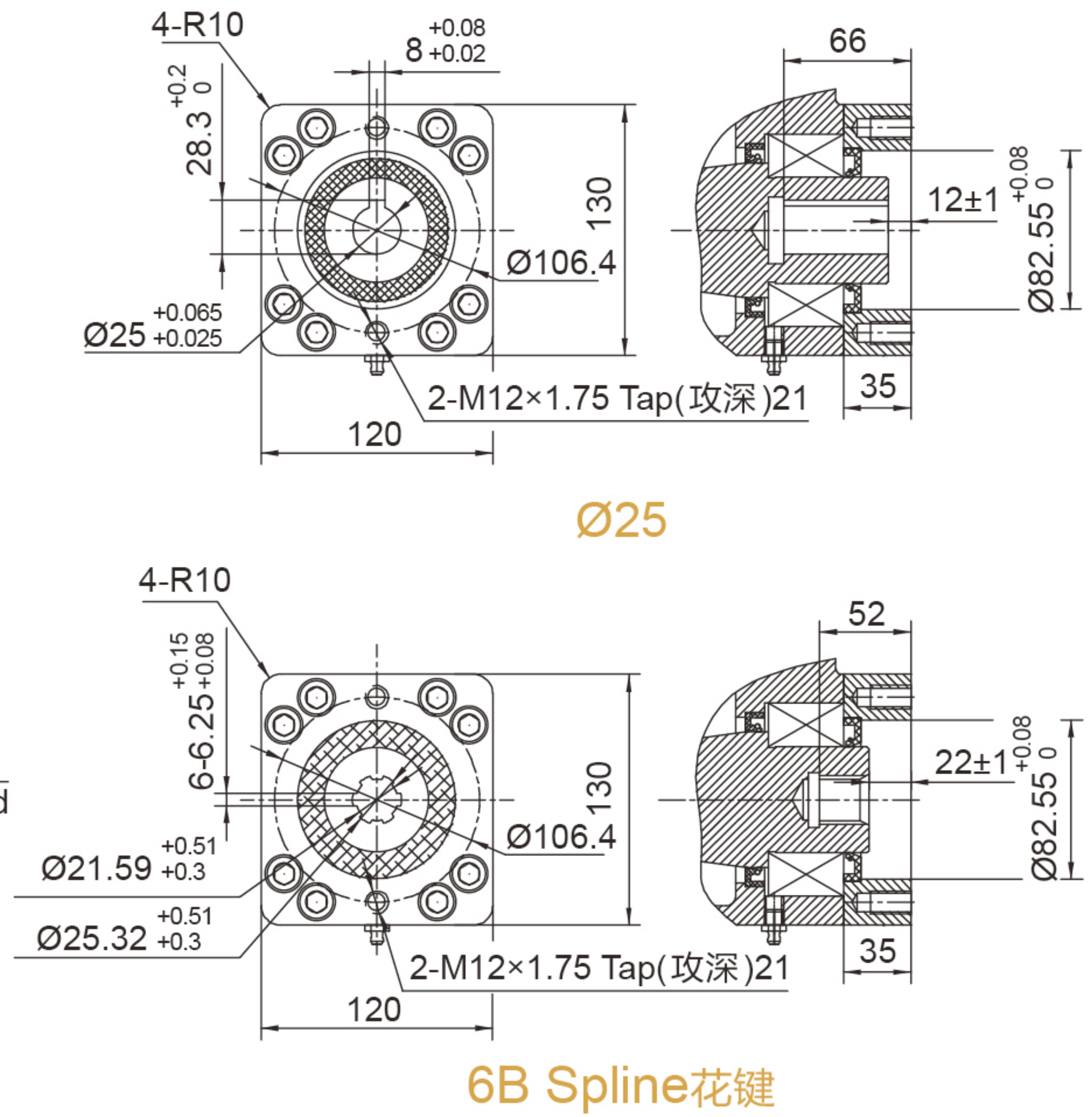

SIDE VIEW 侧视图

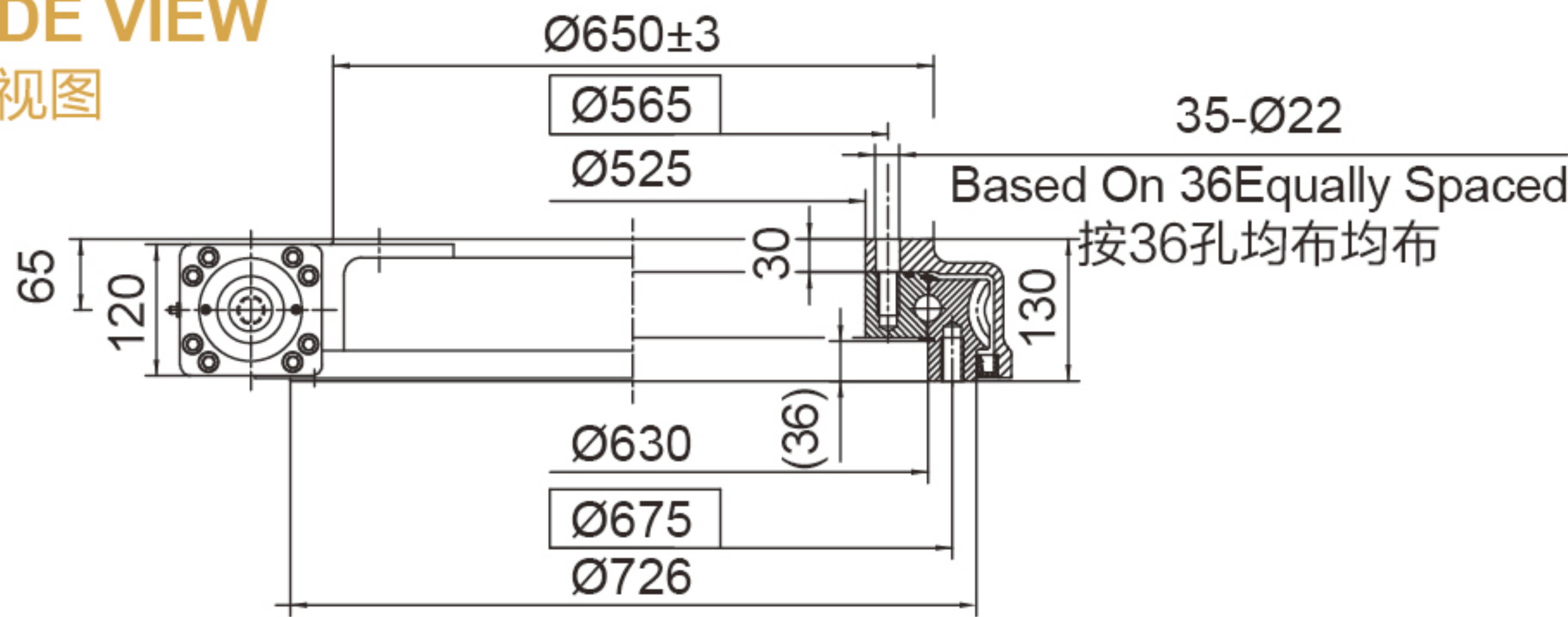

承载力矩图 MOMENT LOAD CHART

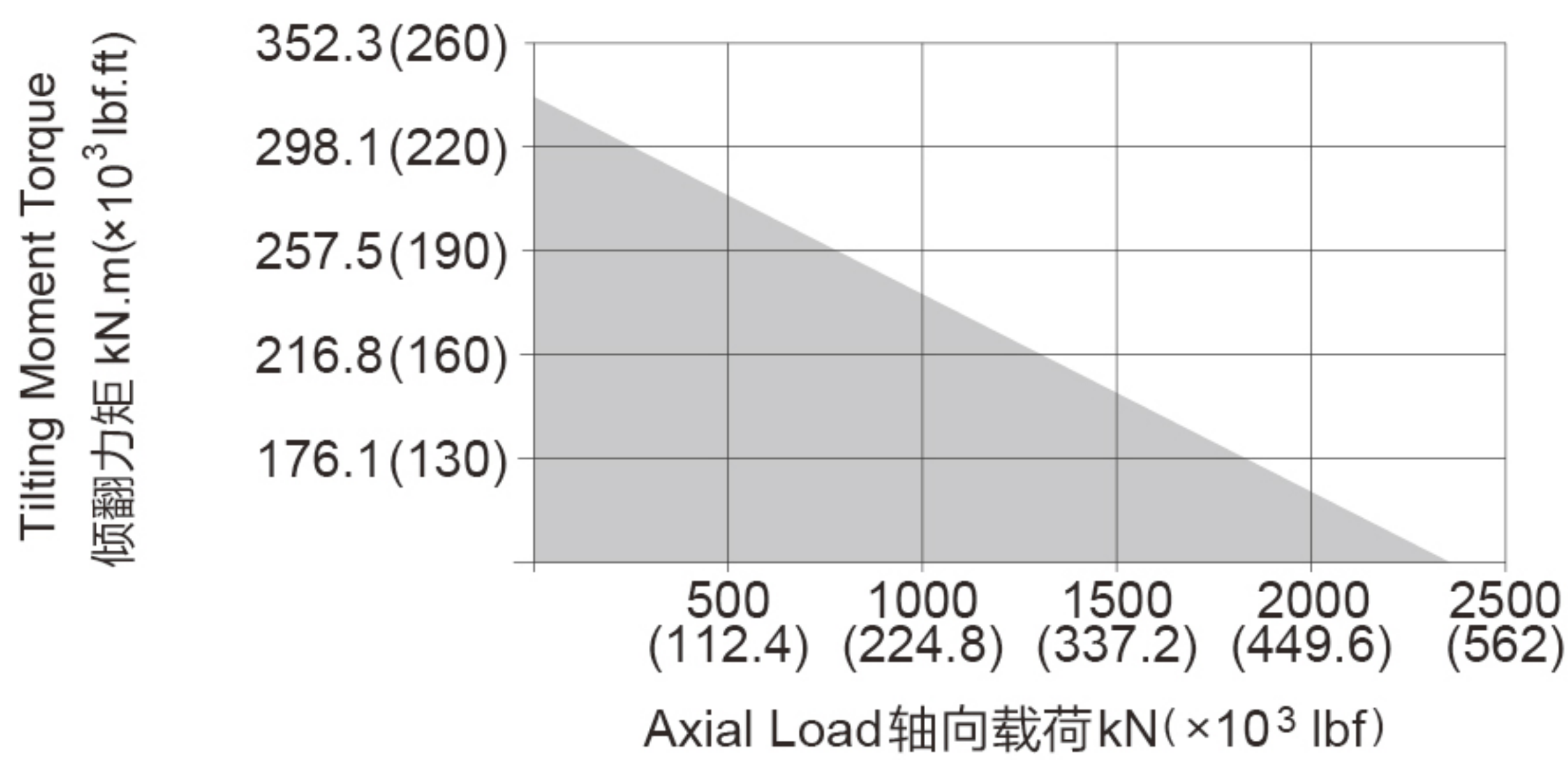

安装孔选项 Mounting Holes Option

Code 代码	M (Outer Ring 外圈)	N (Inner Ring 内圈)
—	M20×2.5 Tap (攻深)40	M20×2.5 Tap (攻深)40
T	M20×2.5 Tap (攻深)40	Ø22 Thru (通孔)
B	3/4"-10UNC-2B Tap (攻深)40	3/4"-10UNC-2B Tap (攻深)40
BT	3/4"-10UNC-2B Tap (攻深)40	Ø22 Thru (通孔)

性能参数表 Slewing Drive Performance Parameters

Output Torque	Tilting Moment Torque	Holding Torque	Static Axial Rating	Static Radial Rating	Dynamic Axial Rating	Dynamic Radial Rating	Gear Ratio	Tracking Precision	Weight
输出转矩	倾覆力矩	保持力矩	轴向静载荷	径向静载荷	轴向动载荷	径向动载荷	减速比	精度等级	重量
34.2 kN.m	310 kN.m	158.3 kN.m	2360 kN	945 kN	590 kN	470 kN	104 : 1	≤ 0.1°	202 kg
25240 lbf.ft	229×10³ lbf.ft	117×10³ lbf.ft	531×10³ lbf	212×10³ lbf	133×10³ lbf	106×10³ lbf			

"A" VIEW AS INPUT IS ALLOWED
输入端允许在 "A" 向视图

SPECIAL DESIGN BASE ON CUSTOMER'S REQUIREMENT
可根据顾客的要求进行非标设计



- Please be sure to remain under the curve.选型时请确保实际载荷在曲线范围内。
- This drawing is just for your refenece.以上图纸仅供参考。
- This drawing is subject to change due to new design without prior notice.本公司保留改进产品的权利而不再另行通知。
- Please contact the technical department for dimensions and performance parameters of the drives.如果需要装置的外形尺寸和性能参考数, 请与技术部门联系。